

INSTALLATION INSTRUCTIONS: **PRE-DRILLED PORTS** **DESIGNATION AND SIZING**

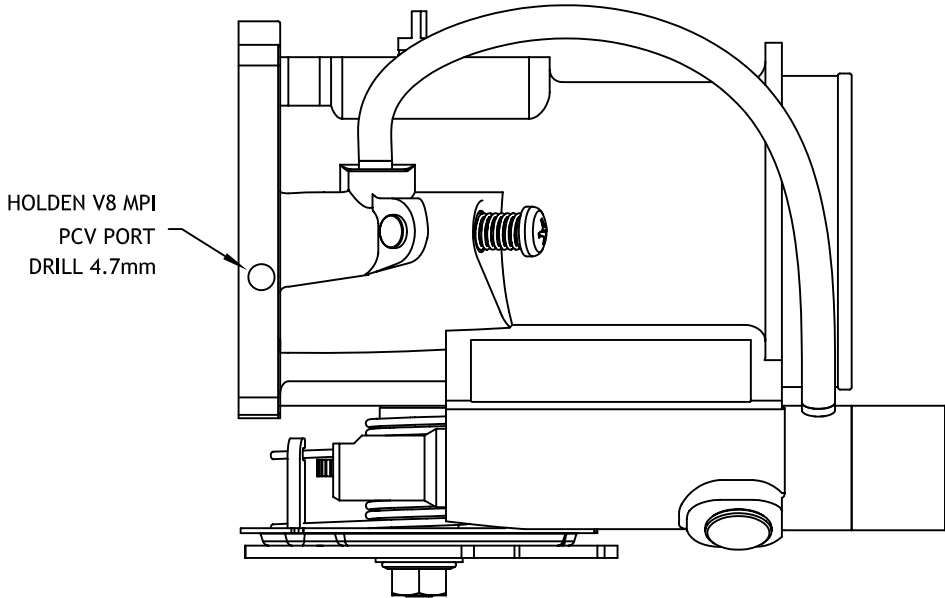

The **GASRESEARCH** Gold Series Throttle Bodies come with partially drilled holes to accommodate vacuum advance, evaporative emission, and vapour injection lines. These holes must be drilled through as required by each application. We recommend that the vacuum advance line only be used with regraphed distributors.

NOTE! To avoid damaging the butterfly, hold the throttle open when drilling.

